

Retarder Prover Room-MASTER

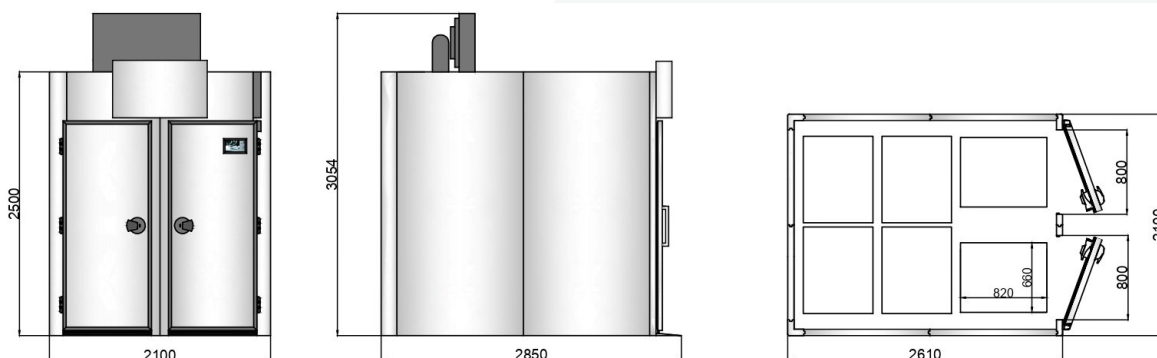

DATA SHEET

External dimensions	mm 2100x2610x2500h
Internal dimensions	mm 1880x2450x1980h
Maximum external height	mm 3100
Structure	Prefabricated modular panels with thickness of insulation 60mm. Polyurethane rigid foam without CFC and density 38/40 Kg/mc. Sanitary profiles on the floor and ceiling
Floor	Without floor
Internal finishing	White painted galvanized sheet
External finishing	White painted galvanized sheet
Doors – entry	n.2 mm 800x2000h – industrial closing
Capacity of racks - trays	n.6 for trays mm 600x800
Evaporator	n.1 with three fans Ø 250mm n.1 with two fans Ø 250mm
Evaporator capacity	6380 Watt a 2°C room / -8°C evaporation
Fans absorption	325 Watt
Tropicalized condensing unit	n.1 ermetic Tecumseh compresor of 4,5Hp with n.2 fans. Dimensions mm 1020x700x554h. Pump Down. High and low pressure switch
Condensing unit capacity	5021 Watt at -10°C evaporation / 38°C condensation
Defrosting resistances	n.1 of 1300 Watt - n.1 of 900 Watt
Heating elements	n.4 of 1800 Watt
Steam generator	n.1 ultrasonic
Temperature range	-5 / +40 °C
Humidity range	50 – 100 %
Temperature probe	n.1 0-10 Volt
Humidity probe	n.1 0-10 Volt
Internal light	n.2 leds of mm500
Master controller	n.1 electronic with touch screen 7"
Voltage	Volt 3x400+N 50Hz
Gas	R452a
Maximum absorption	8,2 Kw.

OPTIONS

Remote Access	Complete remote room management. E-mail alarms notification.
Internal finishing	Stainless steel AISI 304 18/10
External finishing	In gray PET
External front finishing	Stainless steel AISI 304 18/10
Floor – Version A	Phenolic multilayer wood panel thickness 21mm + s/s ramp
Floor – Version B	Insulated and reinforced floor, thickness of insulation 60mm with exposed phenolic multilayer wood panel + s/s ramp
Floor – Version C	Insulated and reinforced floor, thickness of insulation 60mm with anti-slip stainless steel AISI 304 18/10 finishing + s/s ramps.
Remote condensing unit	n.1 Silenced and tropicalized with Tecumseh compressor of 4Hp + accessories – Volt 3x400V+N, 50Hz – distance 10m
Extra heat function	Activating the extra heat function (n.2 of 1800W) in the Manual Proving programme

CODE

MA80-2P-210x261